

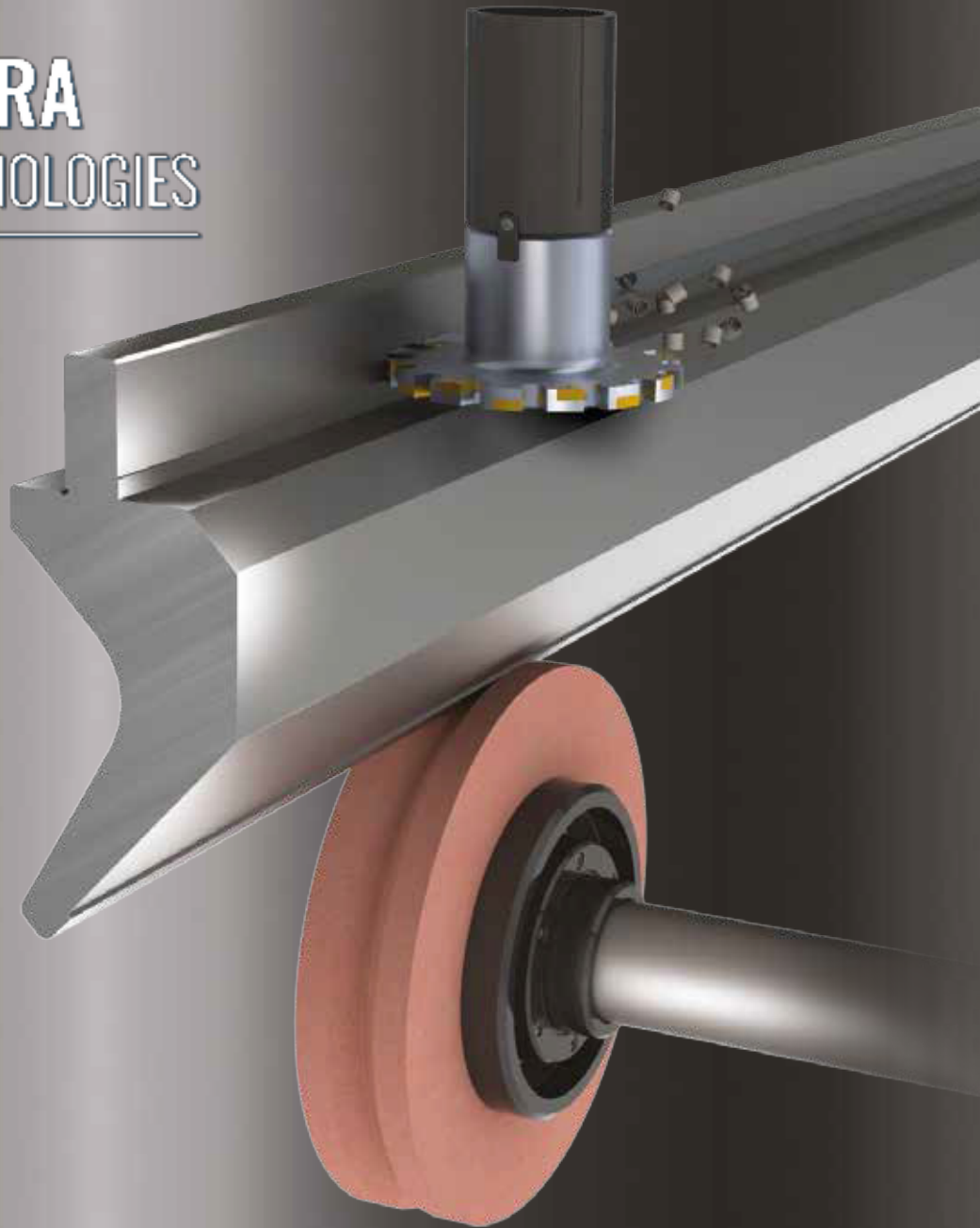

SUPRA
TECHNOLOGIES



UTENSILI PER PRESSE PIEGATRICI



TOOLING FOR PRESS BRAKES



UTILLAJE PARA PLEGADORA



UTILLAJE PARA DOBRADERAS



OUTILS POUR PRESSE PLIEUSE



WERKZEUGE FÜR ABKANTPRESSEN



ED05



SILVER LINE *NE*

WORKING - MODIFICATION - REFURBISHED TOOLING

www.supra-technologies.com



EXPERIENCE & INNOVATION



Da più di 30 anni mettiamo la nostra esperienza al servizio del cliente, progettando e producendo utensili per tutti i tipi di presse piegatrici e cesoie. I prodotti Tecnostamp vengono interamente progettati e costruiti in Italia e commercializzati in tutto il mondo; la nostra azienda offre anche un efficiente servizio post-vendita garantito dalla competenza dei nostri tecnici e dall'assistenza telefonica dell'ufficio commerciale.



For over 30 years Tecnostamp designs and produces tools for all types of press brakes and shears, offering its experience to meet customer requirements. Tecnostamp products are fully designed and produced in Italy and they are sold worldwide; our company also offers an efficient after sales service guaranteed by the experience of our technicians and by the helpline of our sales department.



De más de 30 años, empleamos nuestra experiencia al servicio del cliente, proyectando y produciendo utillajes para todo tipo de prensas plegadoras y cizalladura. Tecnostamp produce en su propia fabrica todos los productos y comercializa en todo el mundo; nuestra empresa también ofrece un servicio post-venta eficiente garantizado por la experiencia de nuestros técnicos y la asistencia telefónica de oficina comercial.



Há mais de 30 anos que colocámos a nossa experiência ao serviço do cliente, projetando e produzindo ferramentas para todos de tipos de quinadoras/dobradeiras e fesoura. Os produtos Tecnostamp são inteiramente projetados e construídos em Itália e comercializados em todo o mundo; a nossa empresa também oferece um serviço pós-venda eficiente garantido pela experiência dos nossos técnicos e pela assistência telefónica de nosso escritório de vendas.



Depuis plus de 30 ans, nous mettons notre expérience au service de la clientèle, avec la conception et la production d'outils pour presses plieuses et cisailles. Les produits Tecnostamp sont entièrement conçus et fabriqués en Italie et vendus dans le monde; notre entreprise offre un service après-vente garanti par la compétence de nos techniciens et l'assistance téléphonique de notre bureau commercial.



Seit mehr als 30 Jahren setzt Tecnostamp seine Erfahrung in der Kundenbetreuung, Entwicklung und der Herstellung von Abkantwerkzeuge für alle Typen von Abkantpressen ein und scher. Unsere Produkte werden komplett in Italien entworfen, hergestellt und weltweit verkauft. Unser Unternehmen bietet Ihnen auch einen effizienten After-Sales-Service durch das Know-How unserer Techniker und die Hotline unseres Vertriebsbüros.



OUR LINES

- RED LINE
- ORANGE LINE
- YELLOW LINE
- GREEN LINE
- BLUE LINE
- MAGENTA LINE
- CORAL LINE
- GOLD LINE
- SILVER LINE
- BLACK LINE
- RAINBOW LINE



RICONDIZIONAMENTO

RICONDIZIONAMENTO - RENOVATION - RENOVACIÓN

- ✓ RIPARAZIONE E RICONDIZIONAMENTO DI STAMPI A RICHIESTA
- ✓ REPAIR AND RENOVATION OF BENDING TOOLING ON REQUEST
- ✓ BAJO PETICION, REPARACIÓN Y RENOVACIÓN DE UTILAJE PARA PLEGADORA

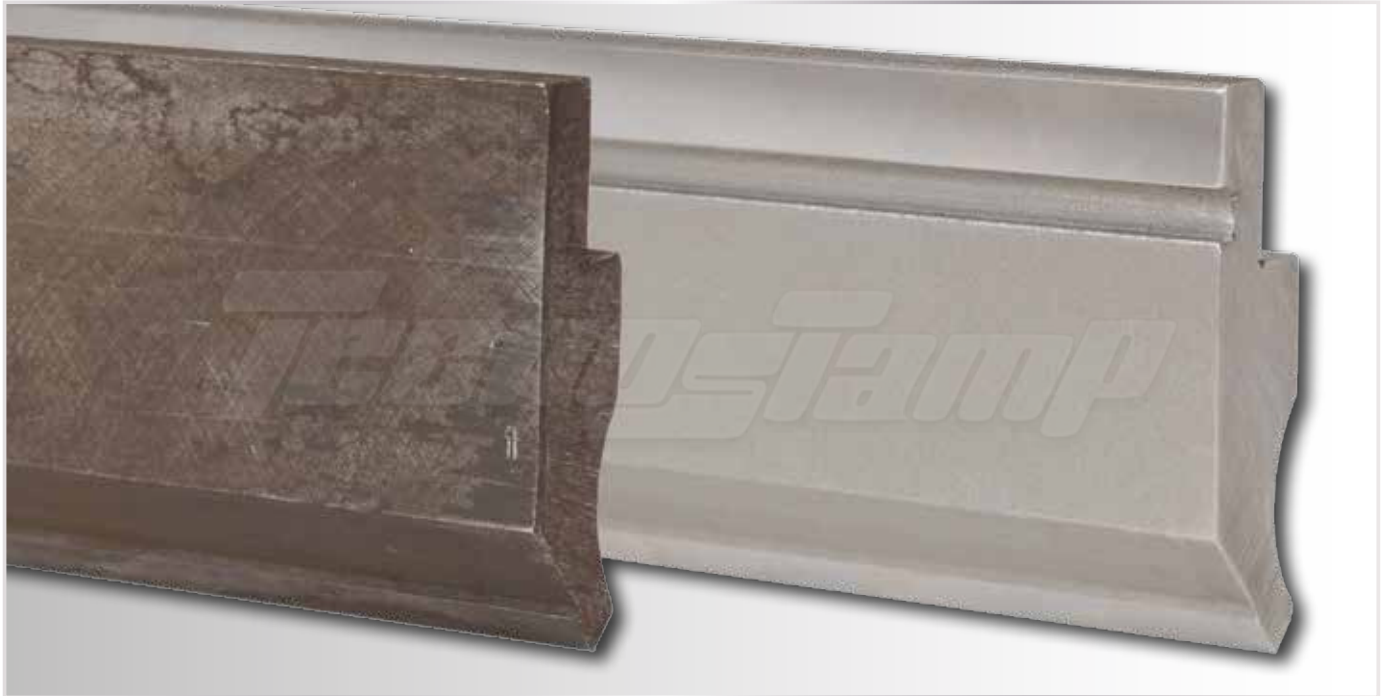

RENOVAÇÃO - RENOVATION - REKONDITIONIERUNG

- ✓ A PEDIDO, REPARACAO E RECONSTRUCAO DAS FERRAMENTAS DE DOBRA
- ✓ REPARATION ET RENOVATION DE OUTILS DE PLIAGE SUR DEMANDE
- ✓ AUF ANFRAGE, ERNEUERUNG GEBRAUCHTER WERKZEUGE



SERVIZIO POST- VENDITA MODIFICHE E LAVORAZIONI

SERVIZI POST VENDITA A RICHIESTA

- ✓ MODIFICHE DI FRESATURA
- ✓ MODIFICHE DI RETTIFICA
- ✓ TAGLI E SCARPETTE A RICHIESTA
- ✓ RICONDIZIONAMENTO DI STAMPI USATI
- ✓ TEMPRA A INDUZIONE
- ✓ NITRURAZIONE
- ✓ NITRO OSSIDAZIONE
- ✓ ZINCATURA A FREDDO
- ✓ CARBONITRURAZIONE
- ✓ BRUNITURA
- ✓ TIMBRATURA AL LASER CUSTOMIZZATA



SERVICE AFTER SALE ON REQUEST



- ✓ MILLING CHANGES
- ✓ GRINDING CHANGES
- ✓ CUTS AND SPECIAL HORNES ON REQUEST
- ✓ RECONDITIONING OF YOUR PRESS-BRAKE TOOLING
- ✓ INDUCTION HARDENING
- ✓ NITRIDING
- ✓ NITRO OXIDATION
- ✓ COLD GALVANIZING
- ✓ CARBONITRIDING
- ✓ BURNISHING
- ✓ CUSTOMIZED STAMPING LASER ON REQUEST

DESPUÉS DE VENTA DE SERVICIOS DE SOLICITUD

- ✓ CAMBIOS DE FRESADO
- ✓ MOLER CAMBIOS
- ✓ CORTES Y ZAPATILLAS BAJO PETICIÓN
- ✓ REACONDICIONAMIENTO DE LOS MOLDES USADOS
- ✓ ENDURECIMIENTO POR INDUCCIÓN
- ✓ NITRURACIÓN
- ✓ LA NITRO OXIDACIÓN
- ✓ GALVANIZACIÓN EN FRÍO
- ✓ CARBONITRURACIÓN
- ✓ BRUÑIDO
- ✓ MARCADO A LASER PERSONALIZADO



SERVIZIO POST- VENDITA MODIFICHE E LAVORAZIONI

DEPOIS DAS VENDAS SERVIÇOS A PEDIDO



- ✓ MUDANÇAS DE FRESAGEM
- ✓ MOAGEM MUDANÇAS
- ✓ CORTES E CHINELOS, MEDIANTE PEDIDO
- ✓ RECONDICIONAMENTO DOS MOLDES UTILIZADOS
- ✓ TÊMPERA POR INDUÇÃO
- ✓ NITRETAÇÃO
- ✓ OXIDAÇÃO NITRO
- ✓ GALVANIZAÇÃO A FRIO
- ✓ CARBONITRIDING
- ✓ POLIMENTO
- ✓ CARIMBAR AOS UTILLAJE DE LASER PERSONALIZADO

SERVICE APRES VENTE SUR DEMANDE

- ✓ CHANGEMENTS DE FRAISAGE
- ✓ BROYAGE DES CHANGEMENTS
- ✓ COUPES ET PANTOUFLES SUR DEMANDE
- ✓ RECONDITIONNER DES MOULES UTILISÉS
- ✓ TREMPE PAR INDUCTION
- ✓ NITRURATION
- ✓ NITRO OXYDATION
- ✓ GALVANISATION À FROID
- ✓ CARBONITRURATION
- ✓ BRUNISSAGE
- ✓ STAMPING AU LASER PERSONNALISÉE



DIENSTLEISTUNGEN AUF ANFRAGE

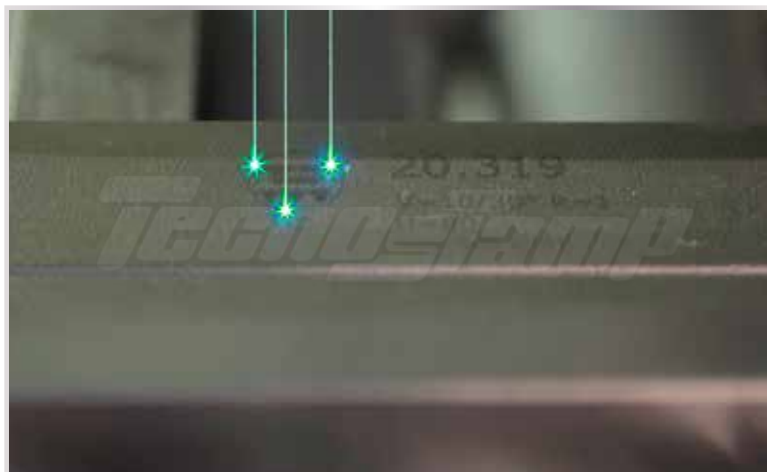

- ✓ ÄNDERUNGEN FRÄSEN
- ✓ ÄNDERUNGEN SCHLEIFEN
- ✓ HORNAUSSCHNITTE AUF ANFRAGE
- ✓ ERNEUERUNG GEBRAUCHTER WERKZEUGE
- ✓ INDUKTIONSHÄRTEN
- ✓ NITRIERUNG
- ✓ NITRO OXIDATION
- ✓ KALTVERZINKUNG
- ✓ KARBONNITRIERUNG
- ✓ BRÜNIERUNG
- ✓ KUNDENBEZOGENE LASERBEZEICHNUNG



PUNZONI



SILVER LINE

WORKING - MODIFICATION - REFURBISHED TOOLING

PUNZONI - PUNCHES - PUNZONES - PUNÇÕES - POINÇONS - OBERWERKZEUGE

LAVORAZIONI SCANALATURE DI SICUREZZA PUNZONI

SCANALATURA DI SICUREZZA TIPO EUROPEO - SAFETY GROOVE EUROPE TYPE - RANURAS DE SEGURIDAD MODELO EUROPEO

RANHURAS DE SEGURANCA MODELO EUROPEU - RAINURE DE SÉCURITÉ MODÈLE EUROPÉEN - SICHERHEITSNUTEN EUROPÄISCHE MODELL

CODE

70.946

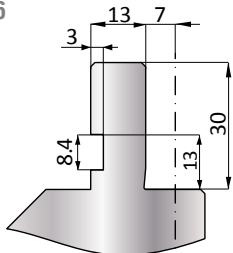

AMADA / PROMECAM

CODE

70.500

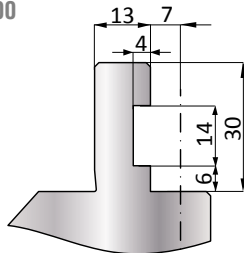

EUROBEYLER

CODE

70.501

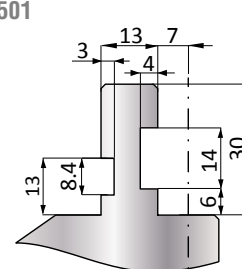

EUROBEYLER - EURO WILA

CODE

70.502

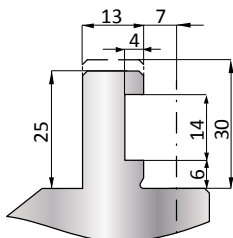

DONEWELL - SAFAN - EUROBEYLER

CODE

70.504

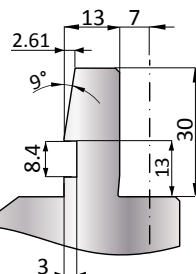

AMADA ONE TOUCH

CODE

70.600

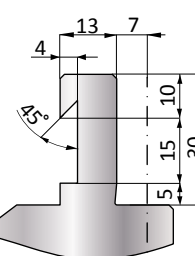

GASPARINI

CODE

70.948

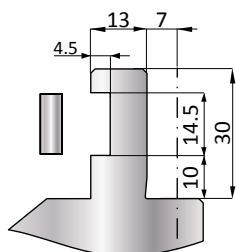

AMADA OLD STYLE

CODE

70.949

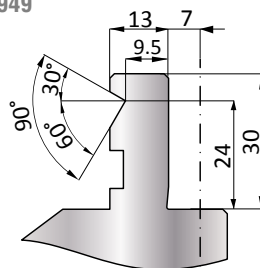

AMADA / BMB IDRAULIC

CODE

70.1050

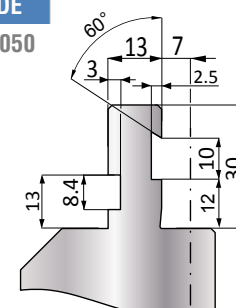

AMADA / PROMECAM (CLARK)



MODIFICHE RAGGIO E ANGOLO PUNZONI

CODE

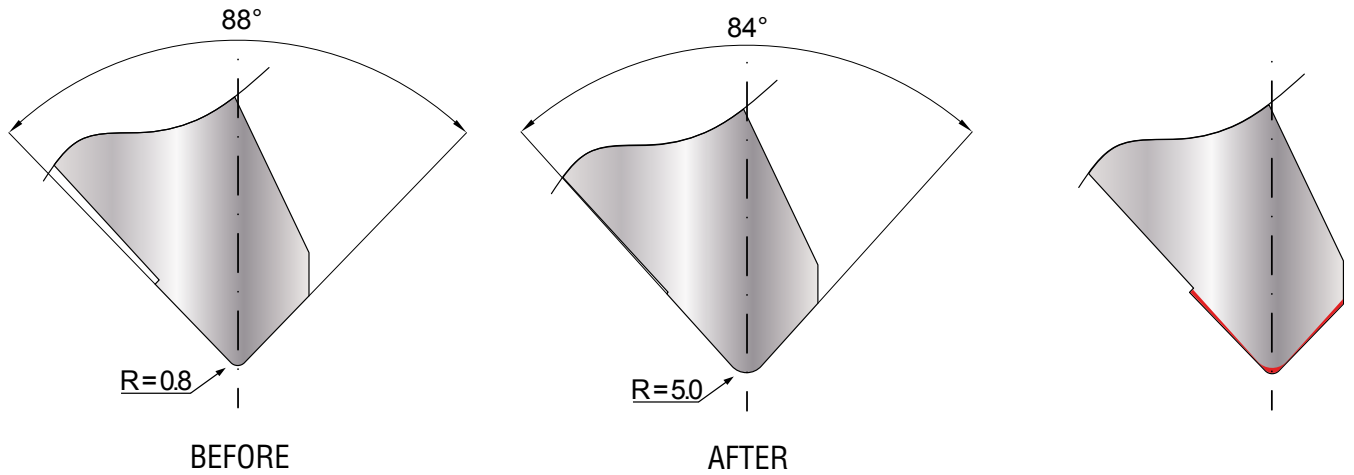

CHANGE OF RADIUS AND ANGLES

CODE

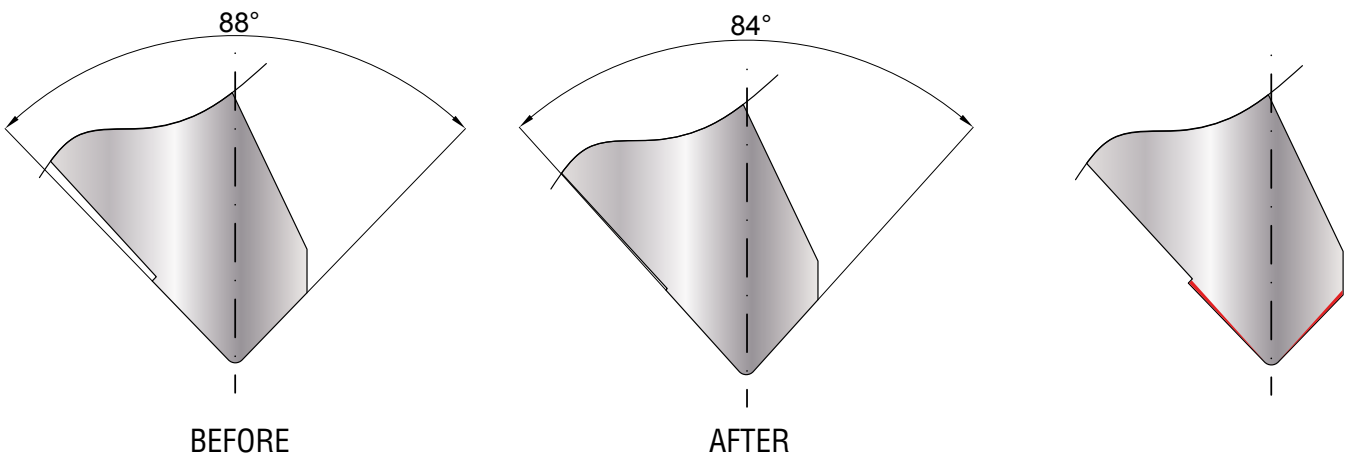

CHANGE OF ANGLES

CODE

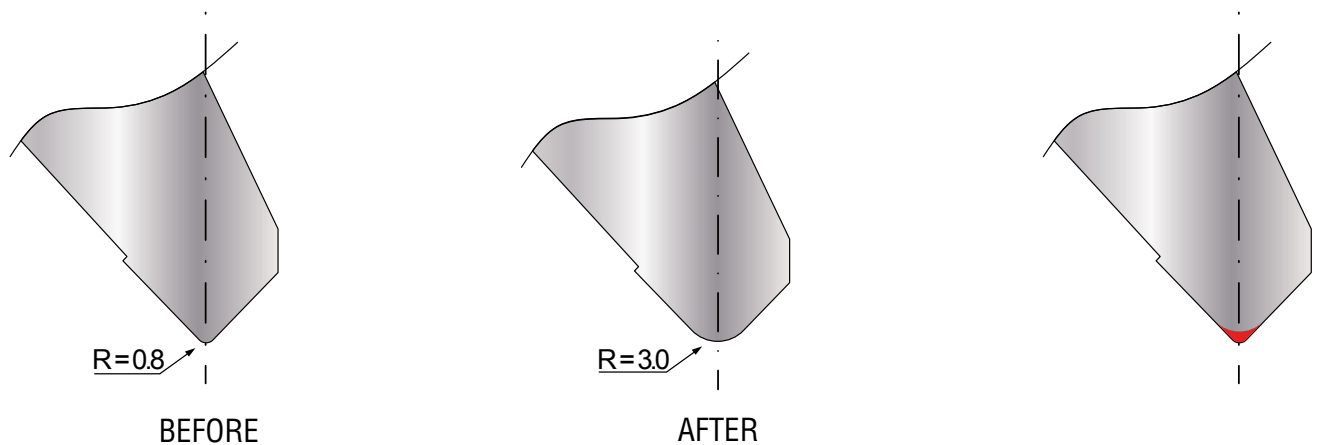

CHANGE OF RADIUS

MODIFICHE RAGGIO E FRAZIONATURA PUNZONI

CODE

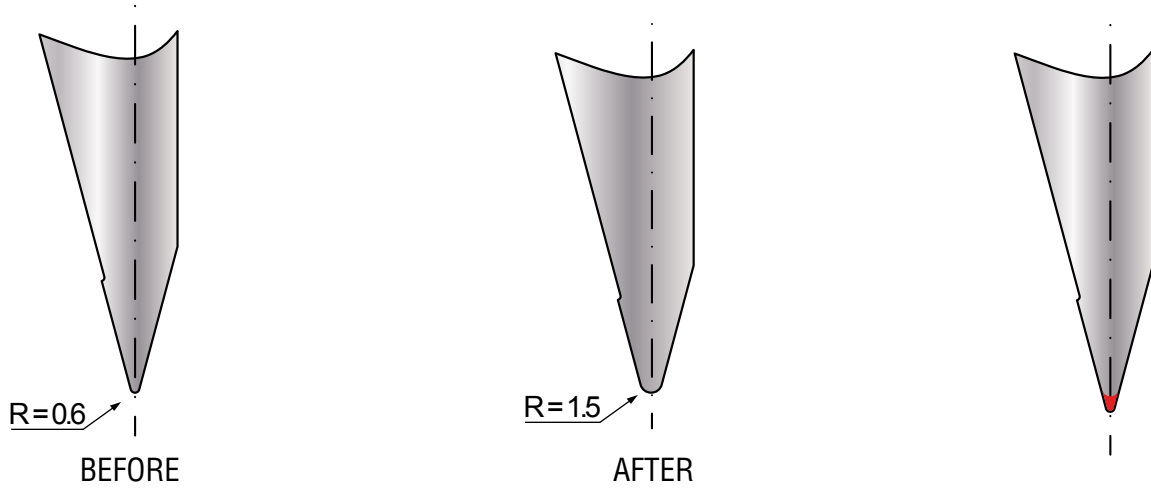

CHANGE OF RADIUS

SPECIFY DIMENSION

- A =
- B =
- C =
- D =

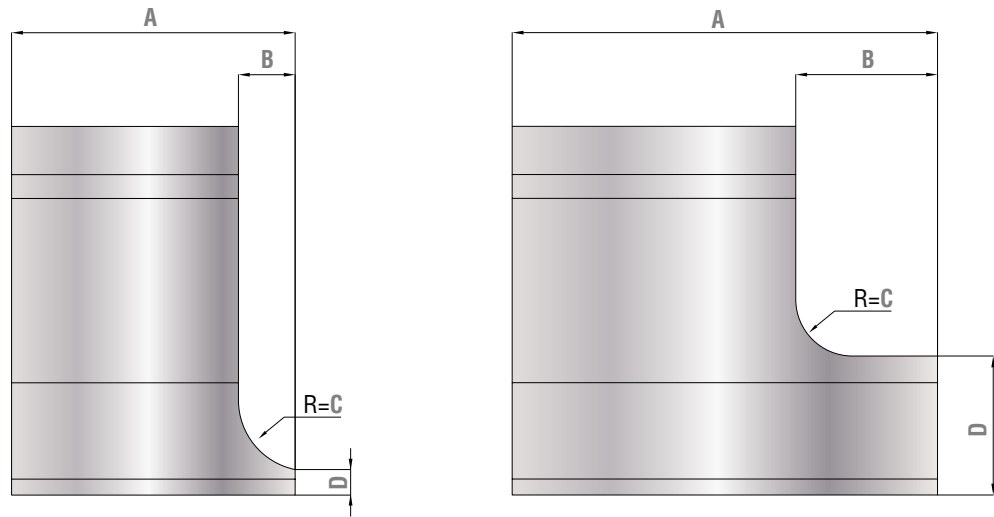

SPECIAL HORNS

SPECIFY DIMENSION

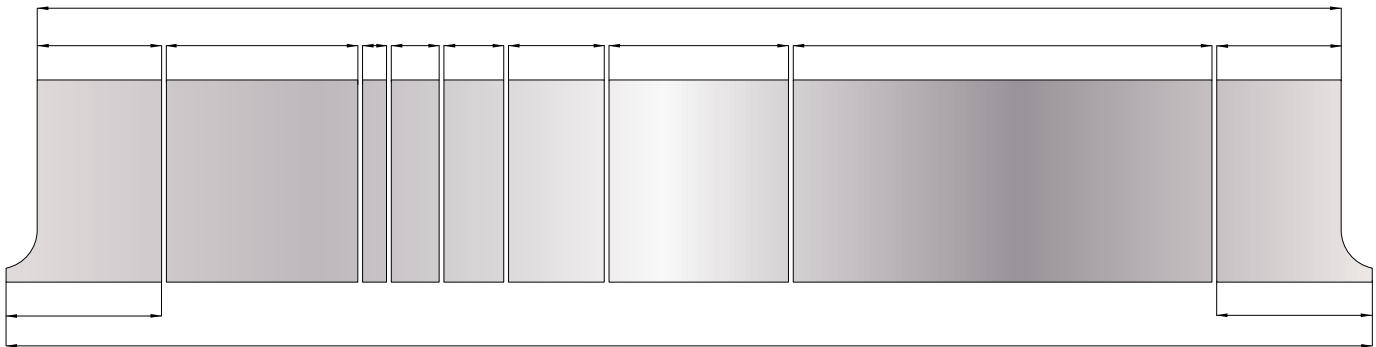

PUNCH SECTIONED ON REQUEST

FRAZIONATURA SPECIALE SU RICHIESTA - SPECIAL CUTTING ON REQUEST - ESPECIAL FRACCIONADO A PETICIÓN
 ESPECIAL FRACCIONADO A PEDIDO - SPECIAL FRACTIONNÉE SUR DEMANDE - SPECIAL SEKTIONERTE AUF ANFRAGE

MODIFICHE PUNZONI

CODE

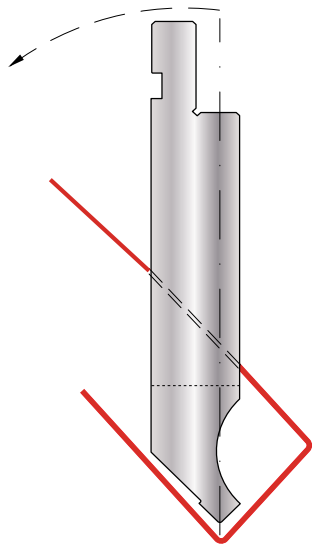

WINDOWS FOR SHORT U PROFILES

CODE

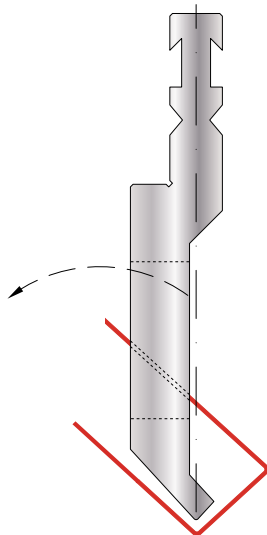

WINDOWS FOR SHORT U PROFILES

CODE

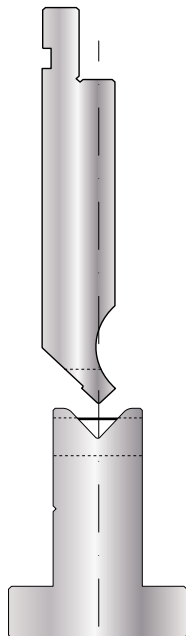

BEADING IN THE BENDING

ESEMPI MODIFICHE PUNZONI STANDARD

CODE

BEFORE

AFTER

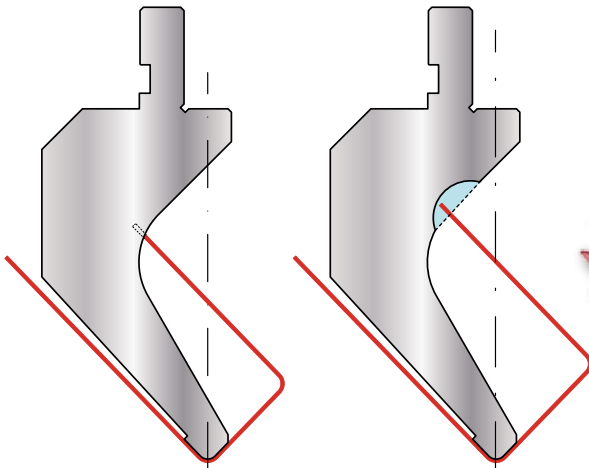

EXAMPLE FOR MODIFICATION

CODE

BEFORE

AFTER

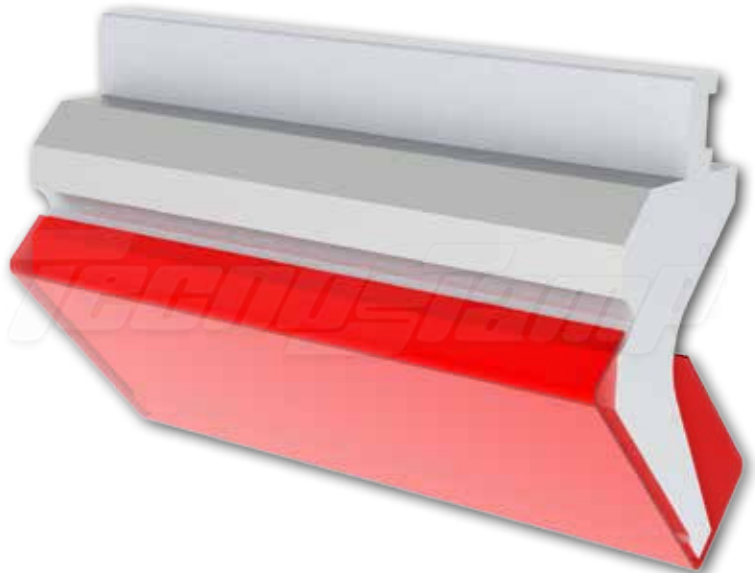
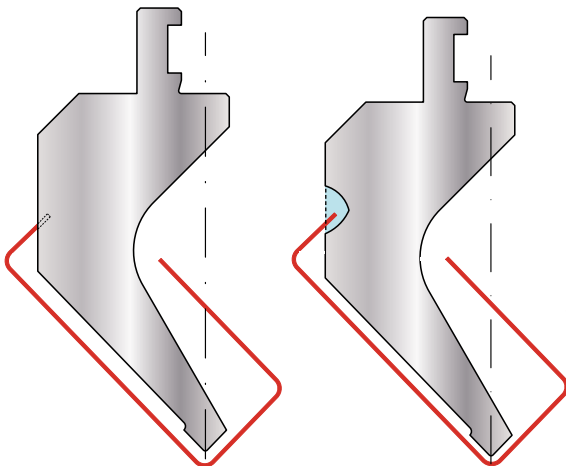

EXAMPLE FOR MODIFICATION

CODE

BEFORE

AFTER

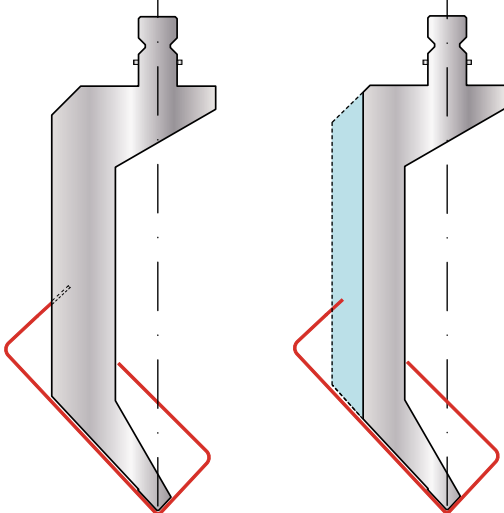

EXAMPLE FOR MODIFICATION

MATRICI



SILVER LINE

WORKING - MODIFICATION - REFURBISHED TOOLING

MATRICI - DIES - MATRICES - MATRIZES - MATRICES - MATRIZEN

MODIFICA RAGGIO E ANGOLO MATRICI

CODE

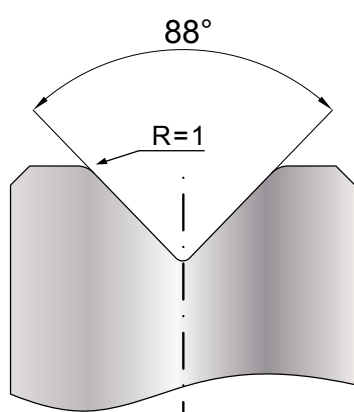

BEFORE

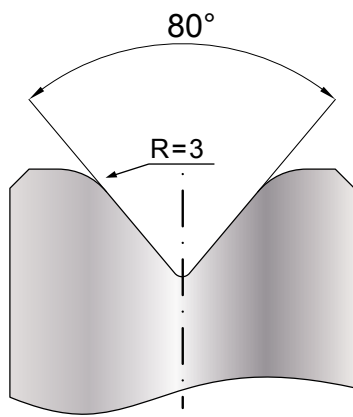

AFTER

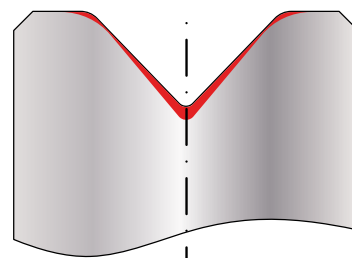

CHANGE OF RADIUS AND ANGLES

CODE

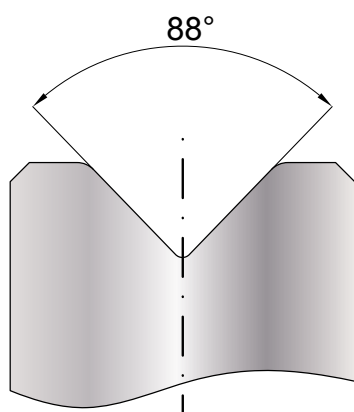

BEFORE

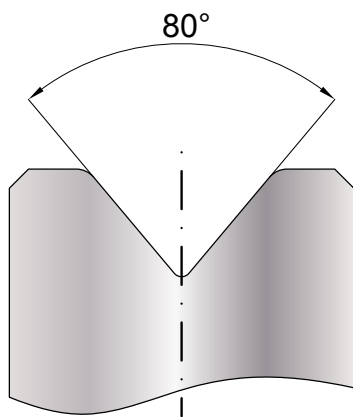

AFTER

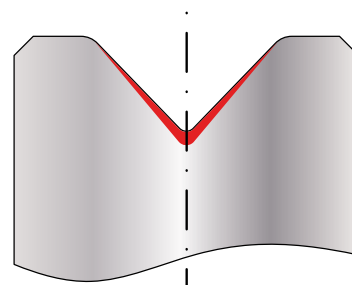

CHANGE OF ANGLES

CODE

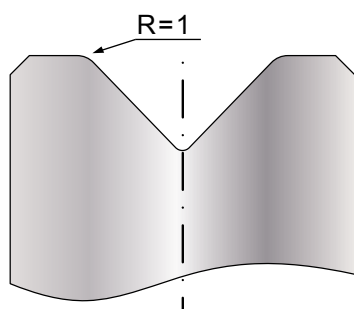

BEFORE

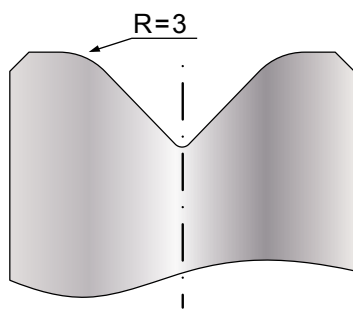

AFTER

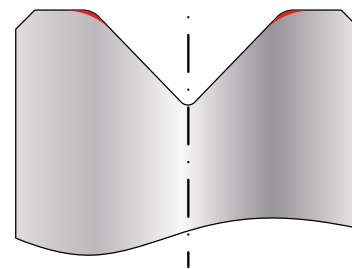

CHANGE OF RADIUS

MODIFICA AMPIEZZA "V" E FRAZIONATURA MATRICI

CODE

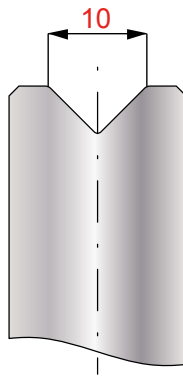

BEFORE

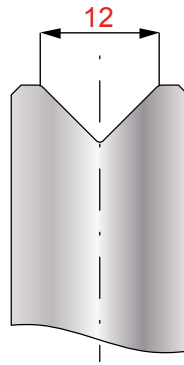

AFTER

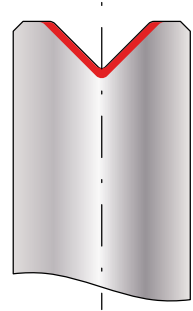

CHANGE OF V OPENING

SPECIFY DIMENSION

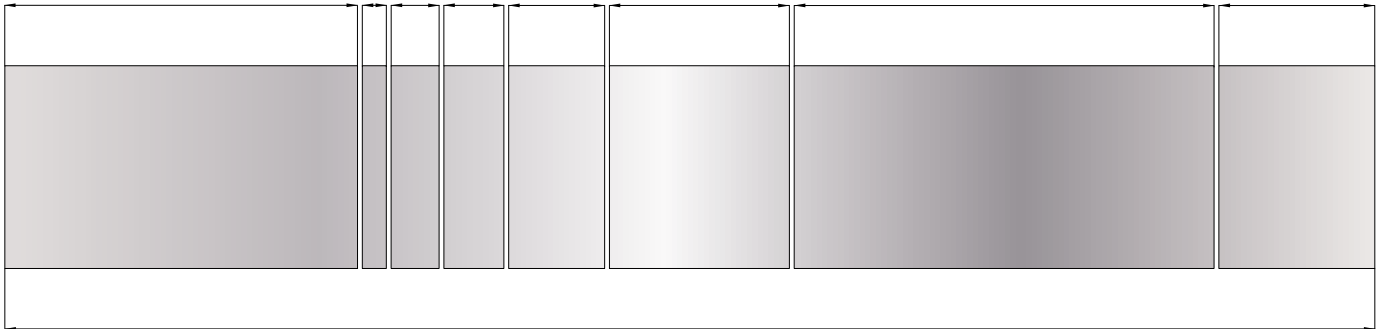

DIES SECTIONED ON REQUEST

FRAZIONATURA SPECIALE SU RICHIESTA - SPECIAL CUTTING ON REQUEST - ESPECIAL FRACCIONADO A PETICIÓN
ESPECIAL FRACIONADO A PEDIDO - SPECIAL FRACTIONNÉE SUR DEMANDE - SPECIAL SEKTIONERTE AUF ANFRAGE

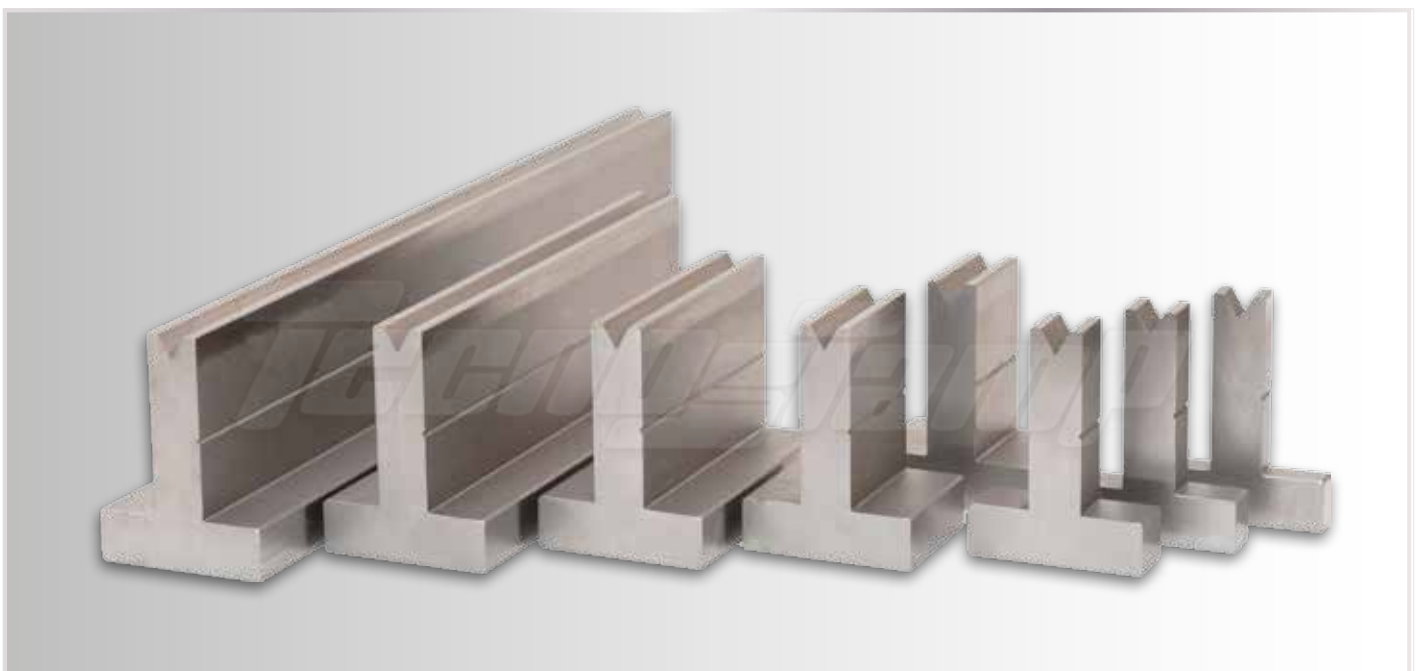

INSERTI MATRICI

CODE

60.100

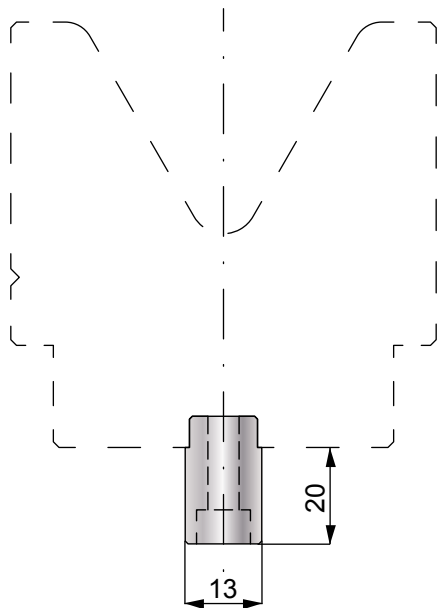

AMADA / TRUMPF - BEYELER

CODE

60.150

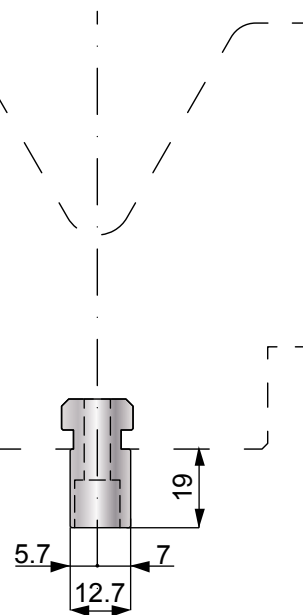

AMADA / LVD

CODE

60.200

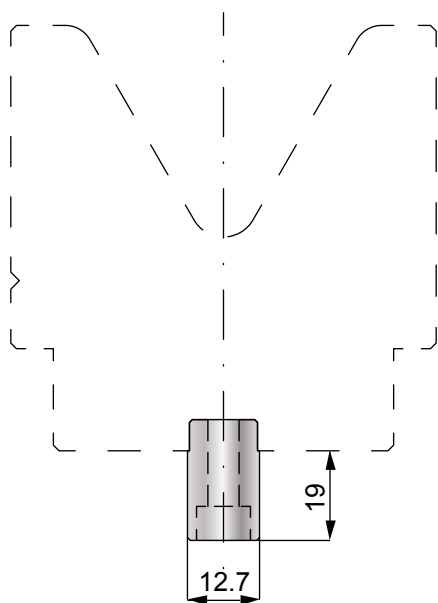

AMADA / AMERICAN



ESEMPI MODIFICHE MATRICI STANDARD

CODE

BEFORE

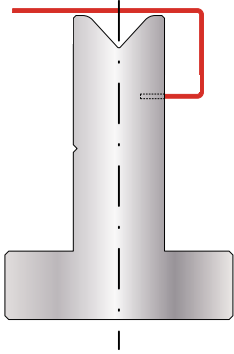

AFTER

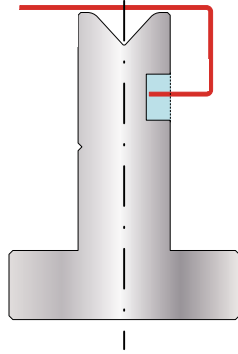

EXAMPLE FOR MODIFICATION

CODE

BEFORE

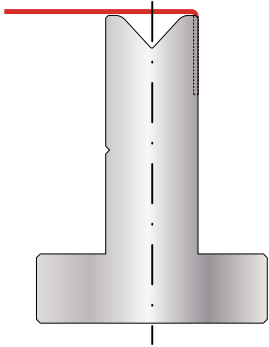

AFTER

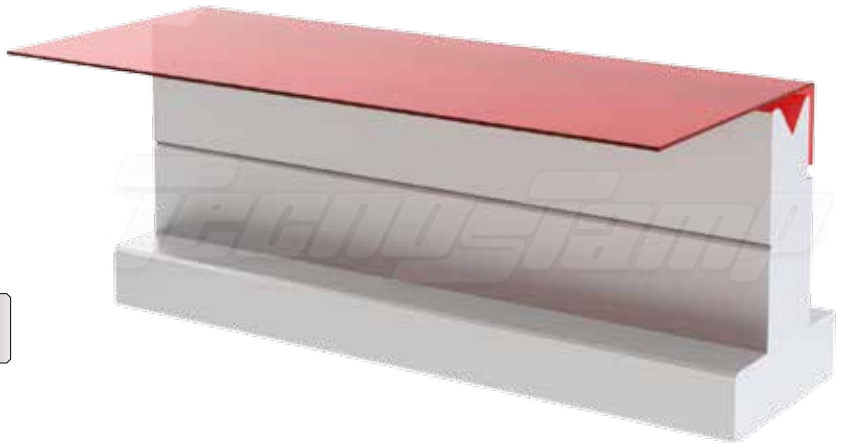
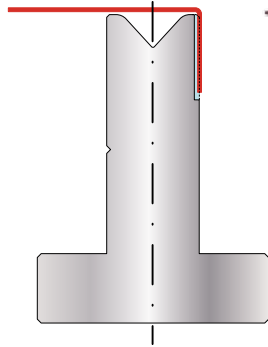

EXAMPLE FOR MODIFICATION

CODE

BEFORE

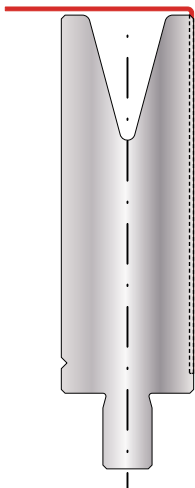

AFTER

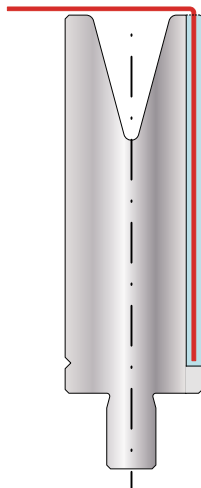

EXAMPLE FOR MODIFICATION

I NOSTRI CATALOGHI

I CATALOGHI SONO DISPONIBILI SUL SITO WEB - THE CATALOGS ARE AVAILABLE ON THE WEBSITE

LOS CATÁLOGOS ESTÁN DISPONIBLES EN EL SITIO WEB - OS CATÁLOGOS ESTÃO DISPONÍVEIS NO SITE

LES CATALOGUES SONT DISPONIBLES SUR LE SITE WEB - DIE KATALOGE SIND AUF DER WEBSITE VERFÜGBAR



RED LINE

AMADA - PROMECAM STYLE



BLUE LINE

WILA - TRUMPF STYLE



ORANGE LINE

BYSTRONIC - BEYELER STYLE



RAINBOW LINE

LVD - EHT - WEINBRENNER - NEWTON STYLE



BLACK LINE

AMERICAN STYLE



CORAL LINE

NO MARKING TOOLS

I NOSTRI CATALOGHI

I CATALOGHI SONO DISPONIBILI SUL SITO WEB - THE CATALOGS ARE AVAILABLE ON THE WEBSITE

LOS CATÁLOGOS ESTÁN DISPONIBLES EN EL SITIO WEB - OS CATÁLOGOS ESTÃO DISPONÍVEIS NO SITE

LES CATALOGUES SONT DISPONIBLES SUR LE SITE WEB - DIE KATALOGE SIND AUF DER WEBSITE VERFÜGBAR



MAGENTA LINE ADAPTERS FOR ALL PRESS BRAKES



YELLOW LINE RECTILINEAR BLADES



GREEN LINE ACCESSORIES FOR ALL PRESS BRAKES



SILVER LINE WORKING - MODIFICATION - REFURBISHED TOOLING



GOLD LINE SPECIAL TOOLING FOR ALL PRESS BRAKES



QR CODE GO TO THE WEBSITE WWW.TECNOSTAMP.EU



SUPRA
TECHNOLOGIES



SFOP - SUPRA Technologies

lieu-dit La Carte - 37380 MONNAIE - FRANCE

Tél. +33 2 47 29 50 - Fax +33 2 47 29 80 59

www.supra-technologies.com - supra@nato-groupe.com